

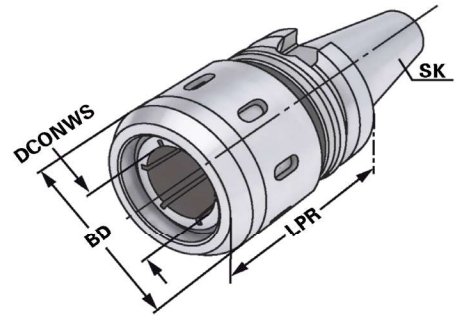

Verwendung:
Zur Aufnahme von Werkzeugen mit Zylinderschaft nach DIN 1835 Form A+B+E und DIN 6535 Form HB+HE

Application:
For mounting straight-shank tools acc. DIN 1835 form A+B+E and DIN 6535 form HB+HE

Application:
Destiné à recevoir les outils avec les queues de forme cylindrique suivant DIN 1835 en forme A+B+E et DIN 6535 en forme HB+HE



ISO 7388-2 Form JD/JF (AD/B) $\leq 3\mu\text{m}$ G6.3 15.000 min⁻¹ HKS

13.04

Bestell-Nr. Order no. Référence	SK	DCONWS Spannbereich Capacity Capacité	Typ	DCONWS	LPR	BD
406.64.20	BT 40	3 - 20	HKS 20	20	90	53
406.64.25	BT 40	3 - 25	HKS 25	25	90	63
406.64.32	BT 40	3 - 32	HKS 32	32	90	68
506.64.20	BT 50	3 - 20	HKS 20	20	95	53
506.64.25	BT 50	3 - 25	HKS 25	25	95	63
506.64.32	BT 50	3 - 32	HKS 32	32	90	68

Größe Size Taille	20mm	25mm	32mm
Anzugsmoment Clamping torque Couple	50-70 Nm	80-100 Nm	80-100 Nm
Spannkraft Clamping force Tension	780 Nm	2000 Nm	2000 Nm

